

# Installation Operation & Maintenance

# JM series

## Condensate neutralizing tubes

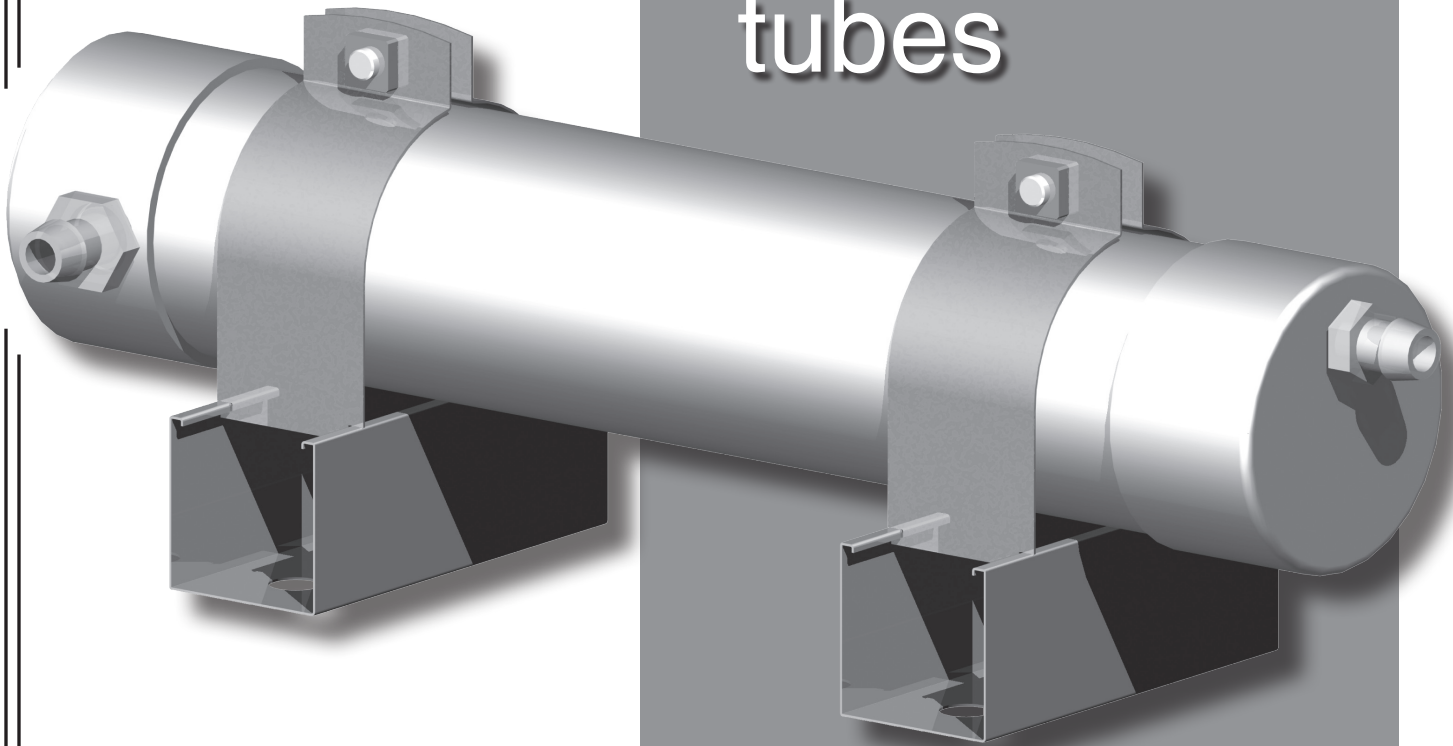

**JJM Boiler Works**

20 Hillside Meadows Drive  
Southampton, MA 01073

Phone 413-527-1893  
web: [www.jjmboilerworks.com](http://www.jjmboilerworks.com)



# Overview

## What is pH?

The pH measurement of a fluid is an indicator of the acidity or alkalinity. Neutral fluids have pH of 7.0. Acid fluids have pH below 7. And alkaline fluids have pH above 7 (up to 14). The pH can be easily measured using litmus paper.

Condensate from condensing boilers and furnaces is typically around 4 (slightly acidic). The condensate needs to be increased (made more neutral) to prevent possible damage to cast iron soil pipe, ABS pipe, septic tanks, plants, wastewater treatment plants and other materials handling waste water.

## JM-series condensate neutralizing tubes increase pH (reduce acidity).

JM-series residential and commercial flue-side neutralizing tubes are designed to raise the pH level of the condensate discharged by high-efficiency boilers and warm air furnaces.

Each change of 1.0 in pH is a 10-times reduction (or increase) in concentration. The pH of condensate is increased by approximately 1.0 to 3.0 higher after passing through JM neutralizing tubes. (This is a change in concentration of from 10 to 30 times.)

**Figure 1** JM-series condensate neutralizing tubes — features and dimensions

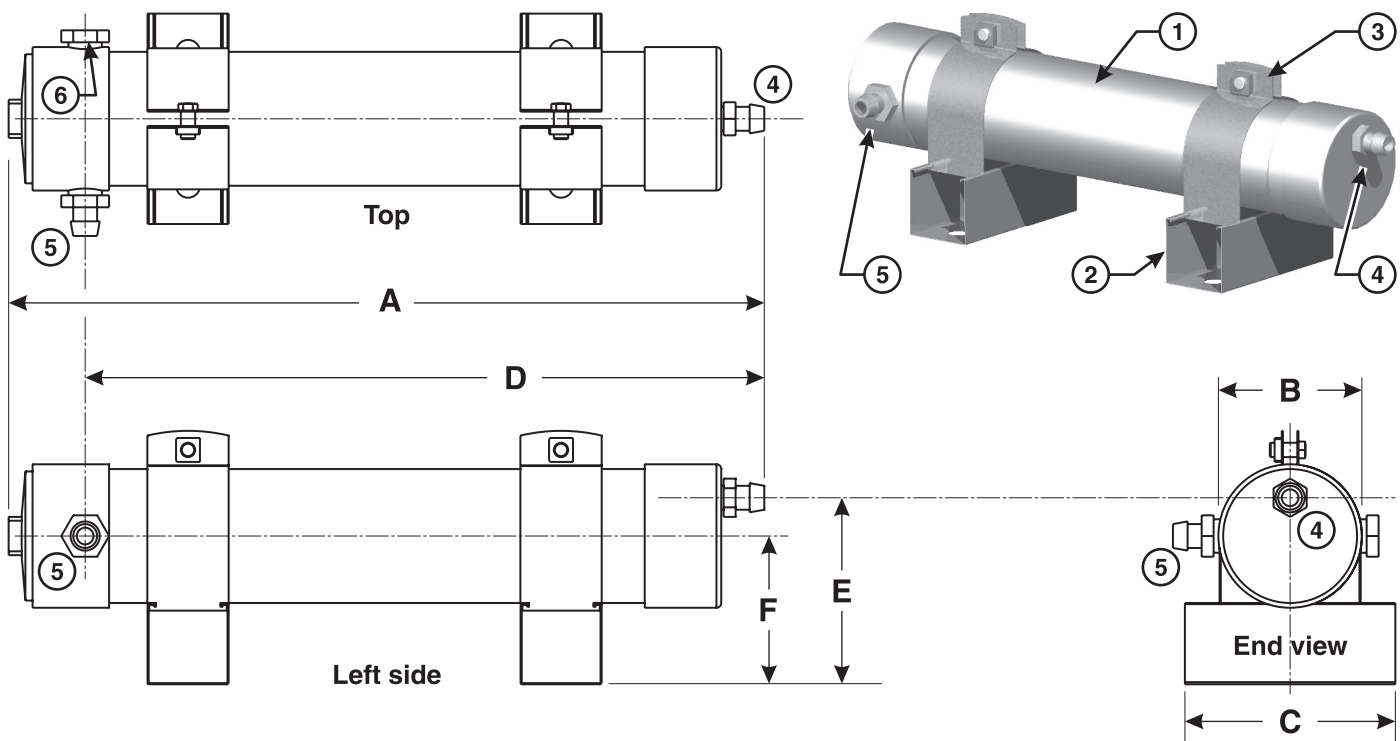

FEATURES			RATINGS & DIMENSIONS (in inches)							
Item	Description	Model	MBH	GPH	A	B	C	D	E	F
1	PVC tubing filled with ½" and ¾" aggregate calcium carbonate	JM-2	200	2	15	2 ¾	3 ⅞	N/A	2 ¼	2 ¼
2	Channel strut mounts	JM-6	600	6	14 ¼	4	6	10 ¾	3 ½	2 ½
3	Galvanized strut clamps, bolts and nuts	JM-10	1,000	10	19	4	6	16 ⅞	3 ½	2 ½
4	Condensate outlet hose barb fitting	JM-20	2,000	20	19 ½	5	6	16 ⅞	4 ½	3 ⅞
5	Condensate inlet hose barb fitting	JM-30	3,000	30	24 ½	5	6	21	4 ½	3 ⅞
6	Plugged — alternate location for condensate inlet hose barb fitting	JM-40	4,000	40	22 ½	7 ⅜	8	19	7 ½	4 ½
		JM-50	5,000	50	28 ½	7 ⅜	8	24	7 ½	4 ½

## Applying JM-series neutralizing tubes

Condensate can be collected from flueways and boiler/furnace condensate trap outlets. Use a separate neutralizing tube for each connection. DO NOT combine condensate lines from flueways with those from boiler/furnace condensate traps. Match neutralizing tubes to boiler/furnace ratings. Locate the JM-series

neutralizing tube below the condensate connection and slightly above the floor drain or inlet to a condensate pump reservoir (if used).

Follow the guidelines in this manual, the boiler/furnace manual and all applicable local codes when installing, using and maintaining JM-series condensate neutralizing tubes.

# Installation

<p><b>WARNING</b></p> <ul style="list-style-type: none"> <li>Application — Flue gas condensing boilers, furnaces, and breeching condensate drains only.</li> <li>DO NOT exhaust flue gases through JM tubes, they are not rated for boiler or furnace flue gases. Operating JM tubes as exhaust vents can cause injury or death from carbon monoxide.</li> <li>DO NOT combine vent condensate drain lines and boiler/furnace condensate lines. Use a separate JM tube for each application.</li> <li>JM tubes must be installed below system P-traps, boiler, furnace, and breeching condensate drains.</li> </ul>	<ul style="list-style-type: none"> <li>Gas traps must be installed between the boiler, vent drains, and furnace condensate outlet and the inlet of all JM tubes.</li> <li>Before operating the boiler or furnace fill the JM tube and traps with tap water.</li> <li>NEVER operate with tubes or P-traps dry.</li> <li>Tubes should be recharged yearly (every 2,000 operating hours), or when pH level moves below 6.</li> <li>Failure to comply with these guidelines could result in severe personal injury, death or substantial property damage.</li> </ul>
--	--

**Figure 2** JM tube application with floor drain, typical

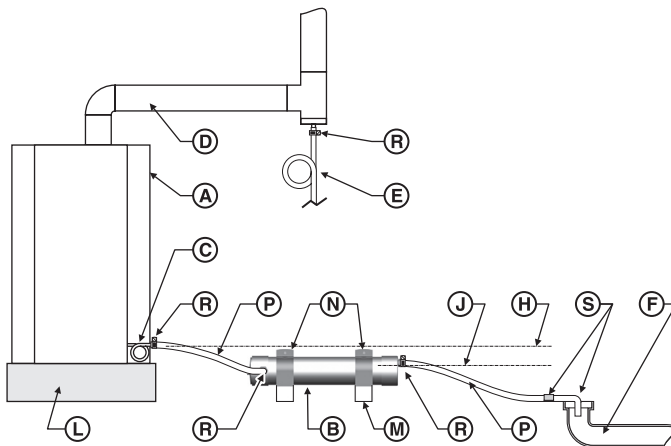

**Figure 3** JM tube application with condensate pump, typical

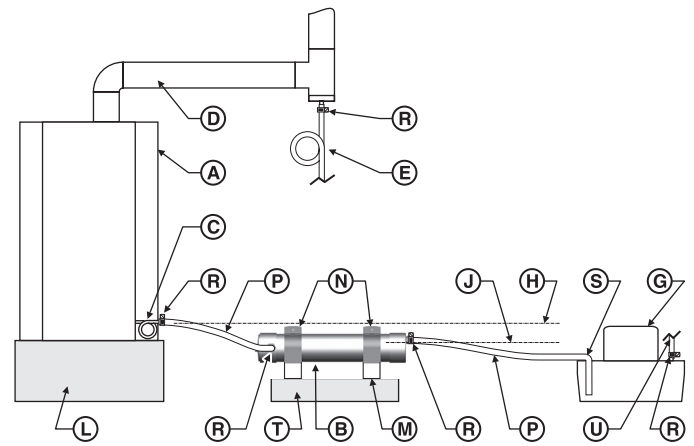

**Legend**

- A** Condensing boiler or furnace
- B** JM condensate neutralizing tube
- C** Boiler/furnace condensate trap connection
- D** Boiler/furnace vent
- E** Vent condensate trap, when used — Install a trap as shown. Connect the tubing to a separate JM tube. DO NOT combine with the boiler/furnace condensate line.
- F** Floor drain or sump
- G** Condensate pump
- H** Bottom of boiler/furnace condensate outlet — MUST be ABOVE bottom of JM tube condensate outlet
- J** Bottom of JM tube condensate outlet
- L** Mounting pad or structural platform, when required to elevate boiler condensate drain as needed
- M** Unistrut bases — bolt to floor, wall or mounting pad
- N** Unistrut clamps — secure tube in position and clamp securely — NOTE that the condensate outlet must be oriented UP, with the condensate inlet into the side.
- P** Plastic tubing or PVC pipe — When using PVC pipe, remove the JM inlet and outlet hose barb fittings and replace with threaded PVC fittings. Include unions in the piping to allow removal of the JM tube for inspection and service. — Secure pipe or tubing in place. — Protect with a shield if necessary if routed through traffic areas.

- R** Use hose clamps at all connections when using plastic tubing.
- S** Condensate drain termination at floor drain or condensate pump reservoir inlet — secure in place with clamps. — Follow instructions for condensate pump.
- T** Elevate the JM tube on a structural base if necessary for the outlet to be raised.
- U** Route discharge line from condensate pump assembly per instructions supplied by pump manufacturer.

**Installation sequence**

1. Securely fasten the two unistrut bases (item M) to floor or wall.
2. Mount tubes across bases and secure with the two unistrut claps (item N).
3. Connect plastic tubes or PVC piping from appliance or breeching drains to P-traps and then from P-trap outlet to either one of the two JM tube inlets.
4. Connect the JM tube outlet to house drain or condensate pump.
5. Use Teflon tape on all threaded plastic fittings.
6. NOTE — Always contact the local authority in regards to any requirements concerning flue gas condensate handling codes.



## Maintenance

### Inspect frequently

Installer — Instruct the building owner to frequently inspect the JM tube and all condensate connections. The owner must notify a qualified technician if any problems are noticed.

### Recharge annually or every 2,000 operating hours

Installer — Have the building owner schedule an annual (or every 2,000 operating hours) recharge of the JM tube. Contact JJM Boiler Works for replacement parts.

<b>WARNING</b>	<ul style="list-style-type: none"> <li>• <b>Before operating the boiler or furnace fill the JM tube and traps with tap water.</b></li> <li>• <b>NEVER operate with tubes or P-traps dry.</b></li> </ul>	<ul style="list-style-type: none"> <li>• Tubes should be recharged yearly (every 2,000 operating hours), or when pH level moves below 6.</li> <li>• Failure to comply with these guidelines could result in severe personal injury, death or substantial property damage.</li> </ul>
----------------	---	--